

Peppers Over The Lake

12 Candlebark Circuit
Jindabyne NSW 2627

Peppers Over The Lake is located in a quiet residential area of town, overlooking Lake Jindabyne. The accommodation consists of 3 bedrooms each with its own new modern bathroom which has thermostat controlled hot water and floor heating. Heated towel racks are supplied in each room as well as clock radios, in-house telephone, safes and electric blankets. All linen is supplied. All of the bedroom/bathroom combinations are spacious and easy to use and one has been specifically set up for access for people with disabilities.

Reservations:

Phone: 02 6456 2575
Web: www.peppersoverthelake.com.au
Email: enquiries@peppersoverthelake.com.au
TTY: n/a

Transport:

Transport is available via private car. An accessible taxi service is available to be booked for transport in and around Jindabyne. Peppers Over The Lake can provide a pick up service if requested.



Parking:

There is a parking area at the end of a steep (19% gradient) driveway. Within this area there is a designated accessible parking space directly outside the entrance. There is plenty of circulation room in the parking area. The surface of the parking area is cement.



Approach and Entry:

The entry to the B&B is directly off the parking area. The path of travel to the entry is less than 10 metres from the parking space. The entry is flat, the door width is 900mm and the door has a lever handle at 1000mm height. The entry/foyer area is tiled. There is no formal reception area, however, the hosts will meet you on arrival.



Bedroom/s:

All 3 rooms at Peppers have flat entry and adequate circulation space. The room they recommend for people with access issues is one that also has its own door to the outside in case of emergency. The entry to this room is through a 900mm wide door which has a lever handle at 1000mm height. The height of the switches in this room is 900mm. There is also a television which has a remote control. The switches are all located further than 500mm from internal corners.

The room has adequate circulation space and a tiled floor. The height of the hanging space in the room is 1300mm. The bed is a queen sized bed on wheels. For transfer there is 1100mm on one side and 600mm on the other side of the bed. The height of the bed is 560mm and there is 130mm space underneath the bed.

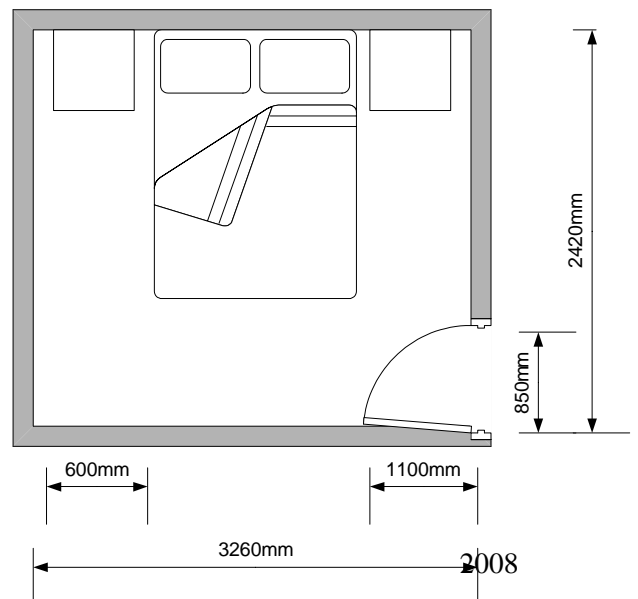

Bathroom:

At Peppers each bedroom has its own bathroom although the accessible bathroom is not ensuite it is across a hall from the bedroom. Entry to the bathroom is through an inwards opening door, minimum width 840mm, which has a lever handle at 1030mm height. There is adequate circulation space in the bathroom, the floor surface is heated tiles.

The shower area is free of steps and hobs and the shower has no shower curtain. There is a single lever mixer tap at 1000mm, a rear horizontal grab rail at 800mm height and a vertical grab rail from 1000 – 1900mm. There is a free standing shower chair with wheels, dimensions are 430mm depth x 430mm width x 500mm height.



The toilet is right hand transfer with 300mm between the toilet and the nearest object (the wall). The distance from the front of the seat to the rear is 730mm and the height of the seat is 470mm. There is horizontal side and rear grab rails at 800mm height and a side vertical grab rail 950-1550mm height.

The washbasin is 800mm high with 700mm knee space and a depth of 470mm. the mirror is 1000mm at its lowest point.

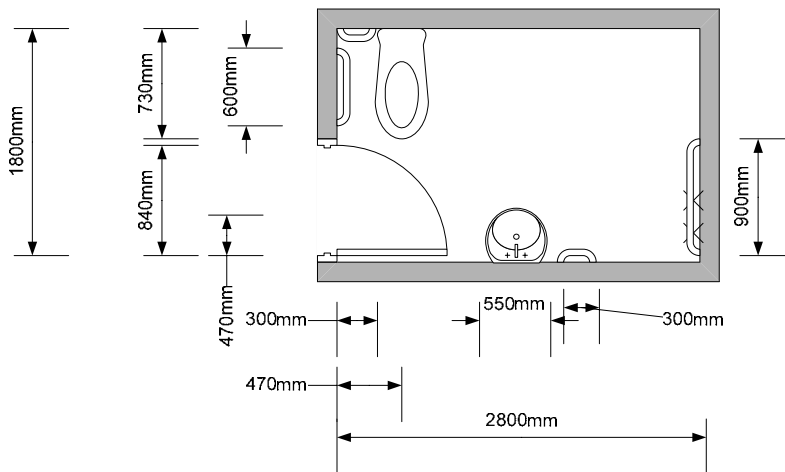

Kitchen/ Dining/ Lounge Area:

The B & B also has a communal kitchen, lounge and dining area. The kitchen bench is at a height of 930mm and the dining table is a height of 740mm with 730mm clear knee space.



Emergency:

A documented emergency procedure is displayed on the door of each room. A Warden will seek to evacuate guests to safe refuge. The building has 2 emergency entry/exit points including slide door flat exit from the accessible room. Exit from the site would be via the driveway.